

Jeffrey A. Houston

+1 (908) 432-9369

jeffrey.a.houston@outlook.com



About me

- Raised outside of Morristown, NJ
- Graduated from Syracuse University, Class of 2020
 - BS, Aerospace Engineering



Professional interests

- Aircraft Design
- Mechatronics
- Product Design
- Renewable Energy

Hobbies

- Snowboarding
- Cooking
- Weight Lifting
- Scuba Diving

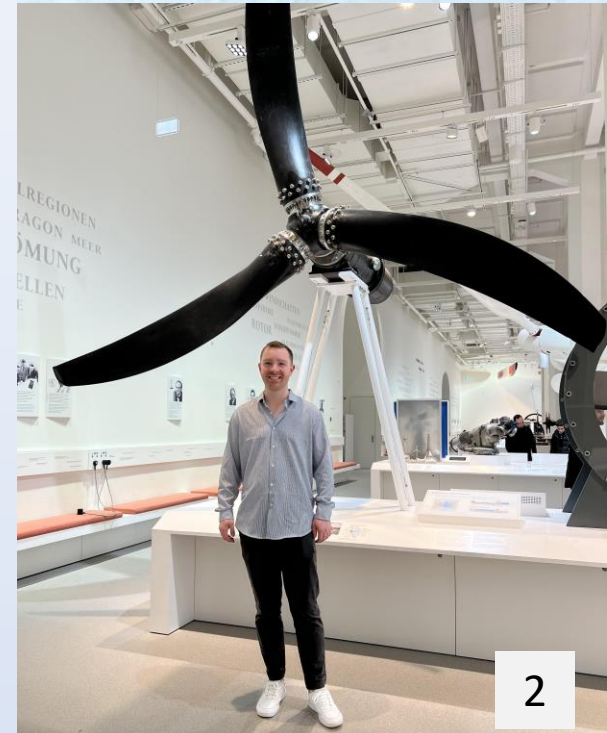

DISCLAIMER: This portfolio only includes projects with publicly available information, and excludes some proprietary projects.

Byrna 12-Gauge Round

Byrna's 12-Gauge round is the safest non-lethal ammunition available on the market today. This is based on its low kinetic energy and high accuracy compared to alternatives.

As the lead engineer on this project, I was able to bring the product from concept to production and incorporate various performance improvements, (30% increase in accuracy).

I was able to analyze ballistics via high-speed camera, conduct a dynamic FEA on a failing part, design injection molded parts for manufacturability, and more.



SCHNEEBERGER, Inc.

SCHNEEBERGER, Inc. is a world leader in manufacturing of linear bearings, and linear motion systems.

My role on the team was to provide design concepts based on changing customer requirements, implement them, assemble/test prototypes, and provide necessary procedures/hardware/software for the production team. I was also in charge of providing customers with bearing recommendations based on fatigue and sizing calculations.

This included creating and modifying CAD assemblies/parts/drawings, building and troubleshooting prototypes, milling simple parts, and performing customers creating assembly instructions

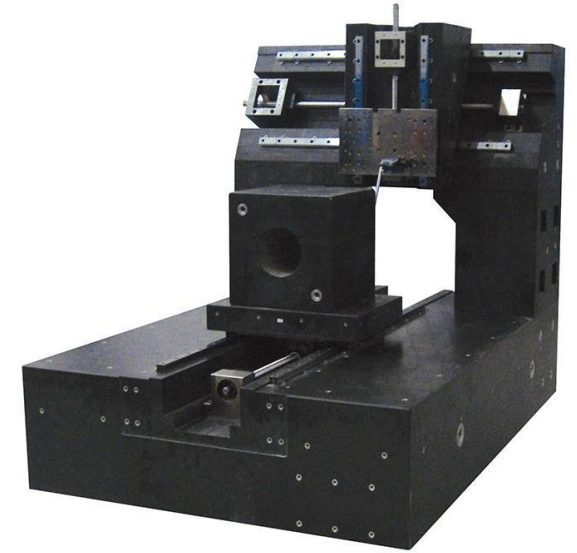

Syracuse StrideMate

The Syracuse StrideMate is an exoskeleton frame used to assist in rehabilitation in paraplegic patients via electrical stimulation of the leg muscle groups. in Syracuse University's Bionics and Control Systems Laboratory

- Product & Mechanical Design
- Design for Manufacturability
- Off-the-shelf Components
- Fabricated via Machining
- Position Feedback
- Force Sensor Calibration

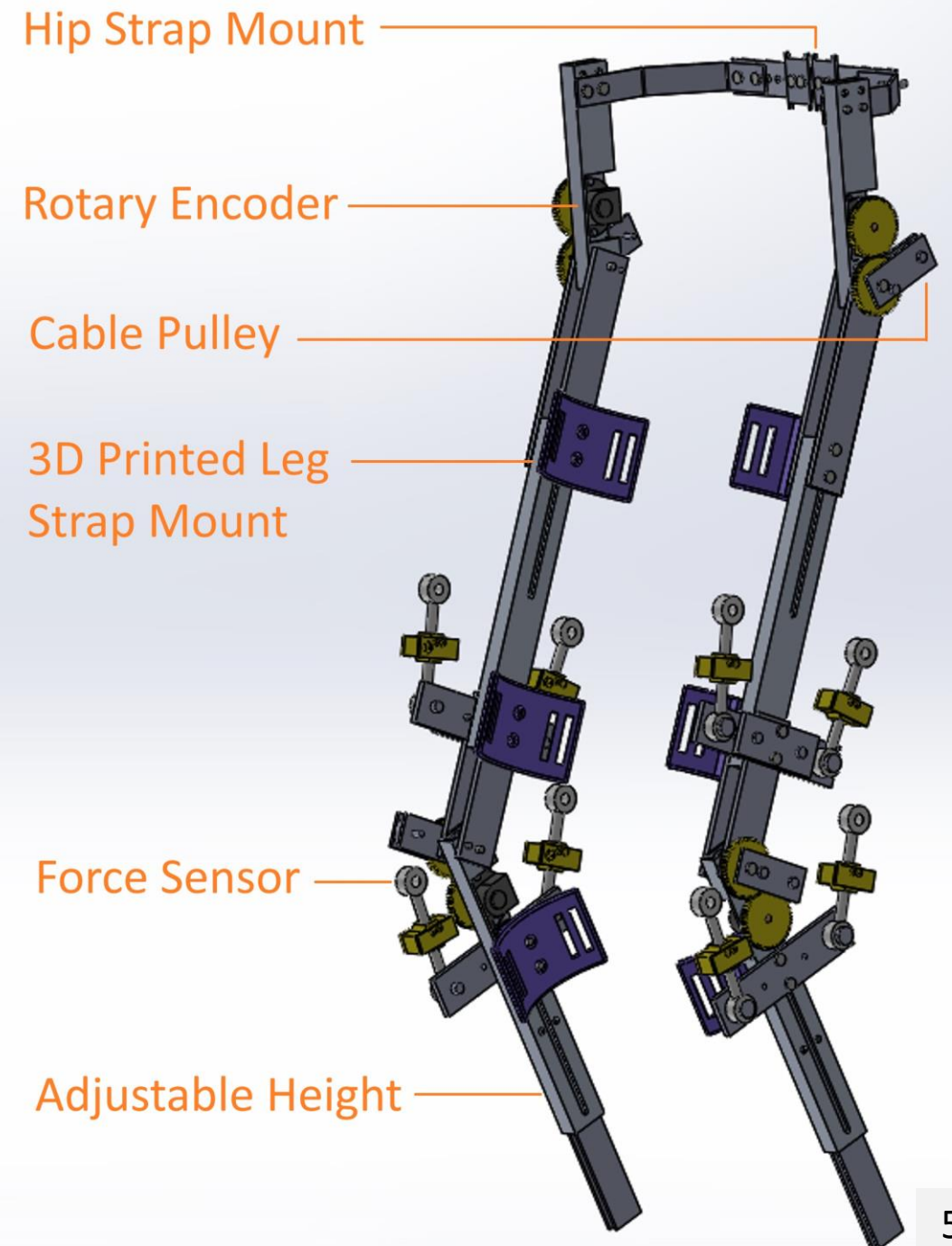

Mustang Aircraft

The Mustang is an RC concept aircraft designed for Syracuse University's Aerospace Engineering Senior Design Competition of 2020.

The aircraft features a bottle rocket payload (pressurized air and water), theoretically balanced design, optimized structural fuselage and wing design in takeoff, SLUF, and throughout slight banks.

Both CAD models were created by me (pre-competition, and post-competition models)

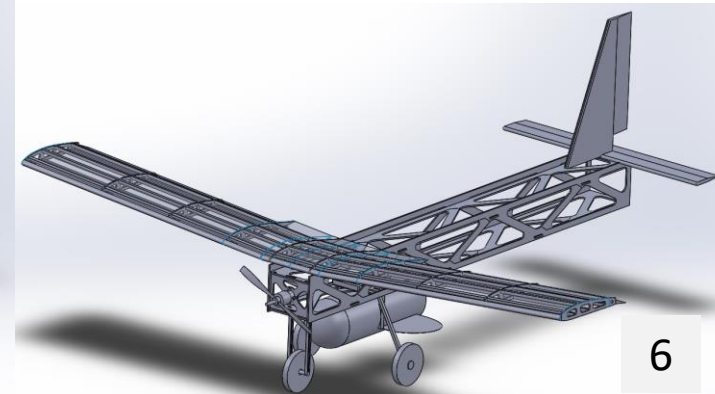
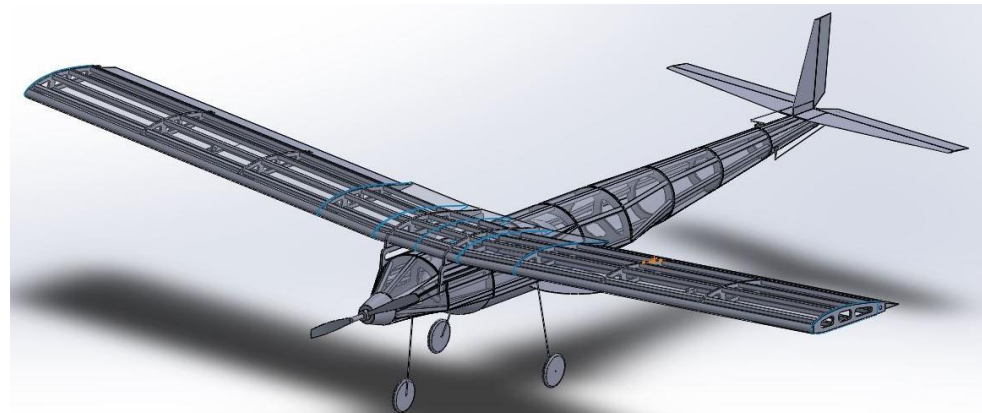

von Mises stress (lb/in²)

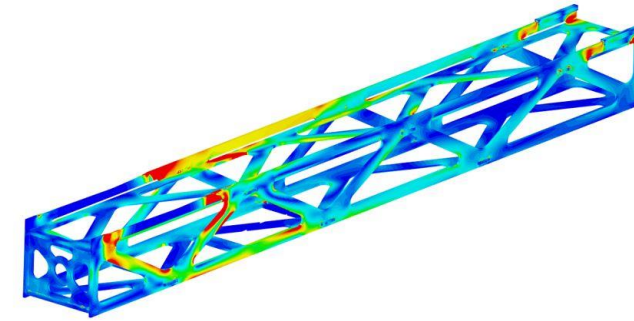
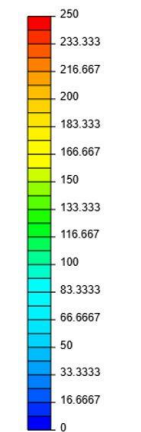

von Mises stress (lb/in²)

